

Threaded or push-in/weld-in protection tube

Design per DIN 43772 form 2, 3, 2G, 3G

Model TW35

WIKA data sheet TW 95.35

Applications

- Chemical industry, process technology, equipment manufacturing
- For low and medium process loads

Special features

- Designs per DIN 43772
- Design TW35-2: Form 2 (straight)
- Design TW35-3: Form 3 (tapered)
- Design TW35-4: Form 2G (straight)
- Design TW35-5: Form 3G (tapered)
- With integrated neck tube
- Designs TW35-3, TW35-5: Fast-response design

Description

Each thermowell/protection tube is an important component of any temperature measuring location. It is used to separate the process from the surrounding area, thus protecting the environment and operating personnel and keeps aggressive media, high pressures and flow rates from the temperature probe itself and thereby enables the thermometer to be exchanged during operation.

Based on the almost limitless application possibilities, there are a large number of variants, such as thermowell designs or materials. The type of process connection and the basic method of manufacture are important design differentiation criteria. A basic differentiation can be made between threaded and weld-in thermowells/protection tubes, and those with flange connections.



Fig. left: Threaded protection tube, design TW35-4 (form 2G)
Fig. right: Push-in/weld-in protection tube, design TW35-3 (form 3)

Furthermore, one can differentiate between protection tubes and thermowells. Protection tubes are constructed from a tube, that is closed at the tip by a welded solid tip. Thermowells are manufactured from solid bar stock.

The TW35 series of threaded or weld-in protection tubes are suitable for use with numerous electrical and mechanical thermometers from WIKA.

Due to their design to DIN 43772, these protection tubes for low and medium process loads are suitable for use in the chemical industry, process technology and equipment manufacturing.

Specifications

Basic information	
Protection tube form	
Design TW35-2	Form 2 (straight)
Design TW35-3	Form 3 (tapered), fast response
Design TW35-4	Form 2G (straight)
Design TW35-5	Form 3G (tapered), fast response
Material (wetted)	Stainless steel 1.4571

Process connection		
Type of process connection	<ul style="list-style-type: none"> ■ G ½ male thread ■ G 1 B male thread ■ M20 x 1.5 male thread ■ ½ NPT male thread ■ For push-in/weld-in Other threads on request	
Connection to thermometer	M24 x 1.5 pressure screw Other threads on request	
Bore size	<ul style="list-style-type: none"> ■ Ø 6.1 mm [0.24 in] ■ Ø 7 mm [0.28 in] ■ Ø 9 mm [0.35 in] 	
Insertion length U_1	To DIN 43772 or customer specification	
Overall length L		
Design TW35-4	Insertion length U_1 + 145 mm [5.7 in]	
Design TW35-5	Insertion length U_1 + 147 mm [5.8 in]	
Suitable stem length l_1 (dial thermometer)		
Connection design S, 4, 4.1, 5, 6.1, 6.2, 6.3 and 7	Parallel thread	$l_1 = L - 10 \text{ mm [0.4 in]}$ or $l_1 = U_1 + M - 10 \text{ mm [0.4 in]}$
	Tapered thread	$l_1 = U_1 + M - 2 \text{ mm [0.08 in]}$
Connection design 2	$l_1 = L - 30 \text{ mm [1.2 in]}$ or $l_1 = U_1 + M - 30 \text{ mm [1.2 in]}$	
Connection design 3	$l_1 = L - 10 \text{ mm [0.4 in]}$ or $l_1 = U_1 + M - 10 \text{ mm [0.4 in]}$	

Operating conditions	
Max. process temperature, process pressure	Depending on: <ul style="list-style-type: none"> ■ Load diagram DIN 43772 ■ Protection tube design <ul style="list-style-type: none"> - Dimensions - Material ■ Process conditions <ul style="list-style-type: none"> - Flow rate - Medium density

Operating conditions

Wake frequency calculation (option)

The calculation in accordance with Dittrich/Klotter of individual thermowells minimises the risk of dynamic damage that can be caused by the vortex shedding of a Kármán vortex street (Vortex Induced Vibration; VIV). In addition, the static loads due to lateral flow and the process pressure are calculated depending on the temperature. The calculation will be carried out as a WIKA engineered service (subject to charges).

→ For further information, see Technical information IN 00.15 "Wake frequency calculation".

Certificates (option)

Certificates

Certificates

- 2.2 test report
- 3.1 inspection certificate

Approvals and certificates, see website

Dimensions in mm [in]

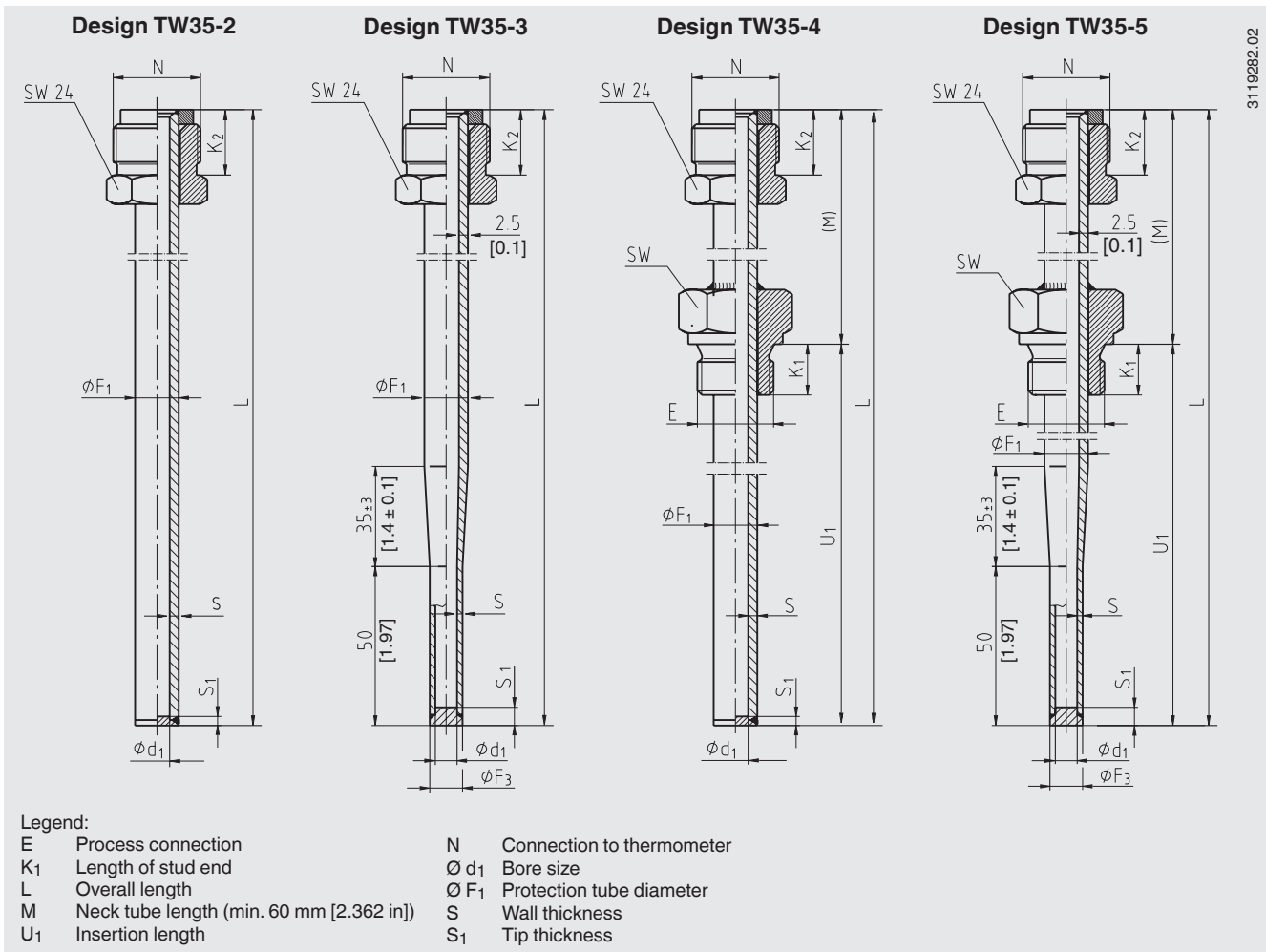

Dimensions in mm [in]					Weight in kg [lbs]
Ø d ₁	Ø F ₁	S	S ₁	E	L = 305 mm [12 in]
7 [0.38]	11 [0.43]	2 [0.08]	3 [0.12]	<ul style="list-style-type: none"> ■ G ½ B ■ G 1 B ■ M20 x 1.5 ■ ½ NPT 	0.23 [0.51]
7 [0.28]	12 [0.47]	2.5 [0.1]	3.5 [0.14]	<ul style="list-style-type: none"> ■ G ½ B ■ G 1 B ■ M20 x 1.5 ■ ½ NPT 	0.35 [0.77]
9 [0.35]	14 [0.55]	2.5 [0.1]	3.5 [0.14]	<ul style="list-style-type: none"> ■ G ½ B ■ G 1 B ■ M20 x 1.5 ■ ½ NPT 	0.23 [0.51]
6.1 [0.24]	12 [0.47]	2.5 [0.1]	6 [0.24]	<ul style="list-style-type: none"> ■ G ½ B ■ G 1 B ■ M20 x 1.5 ■ ½ NPT 	0.23 [0.51]

Ordering information

Model / Protection tube form / Protection tube material / Process connection / Connection to thermometer / Insertion length U₁ / Overall length L / Dimension of pipe / Assembly with thermometer / Certificates / Options

© 12/2007 WIKA Alexander Wiegand SE & Co. KG, all rights reserved.
The specifications given in this document represent the state of engineering at the time of publishing.
We reserve the right to make modifications to the specifications and materials.

