

# Thermowell for lap flanges

## Vanstone design

### Model TW30

WIKA data sheet TW 95.30

#### Applications

- Petrochemical industry, on-/offshore, plant construction
- For high process loads

#### Special features

- Heavy-duty design
- Solid-machined version without weld seam
- Possible thermowell designs:
  - Design TW30-A: Tapered
  - Design TW30-B: Straight
  - Design TW30-C: Stepped
- For lap flanges per ASME B16.5



Thermowell for lap flanges, model TW30

#### Description

Each thermowell/protection tube is an important component of any temperature measuring location. It is used to separate the process from the surrounding area, thus protecting the environment and operating personnel and keeps aggressive media, high pressures and flow rates from the temperature probe itself and thereby enables the thermometer to be exchanged during operation.

Based on the almost limitless application possibilities, there are a large number of variants, such as thermowell designs or materials. The type of process connection and the basic method of manufacture are important design differentiation criteria. A basic differentiation can be made between threaded and weld-in thermowells/protection tubes, and those with flange connections.

Furthermore, one can differentiate between protection tubes and thermowells. Protection tubes are constructed from a tube, that is closed at the tip by a welded solid tip. Thermowells are manufactured from solid bar stock.

The TW30 series of thermowells for lap flanges are suitable for use with numerous electrical and mechanical thermometers from WIKA.

Due to the heavy-duty design, these international design thermowells are the first choice for use in the chemical and petrochemical industries and in plant construction.

## Specifications

Basic information	
<b>Thermowell form</b>	
Design TW30-A	Tapered
Design TW30-B	Straight
Design TW30-C	Stepped
<b>Material (wetted)</b>	<ul style="list-style-type: none"> <li>■ Stainless steel 316/316L</li> <li>■ Stainless steel 304/304L</li> <li>■ A105</li> <li>■ Stainless steel 1.4571</li> <li>■ Alloy C4</li> <li>■ Alloy C276</li> <li>■ Alloy 400</li> <li>■ Titanium grade 2</li> <li>■ Materials in accordance with ASTM specifications</li> </ul>
	→ Other materials on request

Process connection		
<b>Type of process connection</b>	Clamped between mating flanges	
<b>Connection to thermometer</b>	<ul style="list-style-type: none"> <li>■ ½ NPT female thread</li> <li>■ G ½ female thread</li> </ul>	
	→ Other threads on request	
<b>Bore size</b>	<ul style="list-style-type: none"> <li>■ Ø 6.6 mm [0.260 in]</li> <li>■ Ø 8.5 mm [0.355 in]</li> </ul>	
<b>Insertion length U</b>	<ul style="list-style-type: none"> <li>■ 150 mm [5.9 in]</li> <li>■ 200 mm [7.87 in]</li> <li>■ 250 mm [9.84 in]</li> <li>■ 300 mm [11.81 in]</li> <li>■ 350 mm [13.78 in]</li> <li>■ 400 mm [15.75 in]</li> </ul>	
	<ul style="list-style-type: none"> <li>■ 6 in [152 mm]</li> <li>■ 7 in [178 mm]</li> <li>■ 10 in [254 mm]</li> <li>■ 13 in [330 mm]</li> <li>■ 16 in [406 mm]</li> </ul>	
	→ Other insertion lengths on request	
Min. insertion length	Depending on the selected version	
Max. insertion length <sup>1)</sup>	800 mm [31.5 in]	
<b>Connection length H</b>	<ul style="list-style-type: none"> <li>■ 57 mm [2.25 in]</li> <li>■ 83 mm [3.25 in]</li> </ul>	
	→ Other connection lengths on request	
Min. Connection length	Depending on the selected version	
Max. Connection length	250 mm [10 in]	
<b>Tip thickness</b>	6.4 mm [0.25 in]	
	→ Other tip thicknesses on request	
<b>Suitable stem lengths I<sub>1</sub> (dial thermometer) with tip thickness 6.4 mm [0.25 in]</b>		
Connection design S, 4, 4.1, 5, 6.1, 6.2, 6.3 and 7	Parallel thread	I <sub>1</sub> = U + H - 10 mm [0.4 in]
	Tapered thread	I <sub>1</sub> = U + H - 2 mm [0.08 in]
Connection design 2		I <sub>1</sub> = U + H - 30 mm [1.2 in]
<b>Sealing face diameter per ASME B16.5 (raised face RF)</b>		
With DN 1"		51 mm [2.079 in]
With DN 1 ½"		73 mm [2.874 in]
With DN 2"		92 mm [3.622 in]

Process connection			
Sealing face roughness	Design	AARH in µinch	Ra in µm
ASME B16.5	Stock finish	125 ... 250	3.2 ... 6.3
	Smooth finish	< 125	< 3.2

1) Longer insertion lengths in one-piece design are dependent on the geometry and material, and are possible up to 1575 mm (62 in) on request. Basically, from an insertion length of 800 mm (31.5 in), a multi-part assembly in accordance with IN 00.16 is carried out, unless otherwise requested. A wake frequency calculation in accordance with ASME PTC 19.3 TW-2016 requires compliance with the requirements of the above-mentioned standard.

Operating conditions	
<b>Max. process temperature, process pressure</b>	Depending on: <ul style="list-style-type: none"> <li>■ Thermowell design               <ul style="list-style-type: none"> <li>- Dimensions</li> <li>- Material</li> <li>- Flange pressure rating of the lap flange</li> </ul> </li> <li>■ Process conditions               <ul style="list-style-type: none"> <li>- Flow rate</li> <li>- Medium density</li> </ul> </li> </ul>
<b>Hydrostatic pressure test</b>	This non-destructive testing is performed in accordance with ASME B31.3 using the pressure values of the flange standard ASME B16.5 depending on pressure rating, temperature range and material within the associated pressure-temperature table.  The TW30 thermowell material used is used as the flange material.
<b>Wake frequency calculation (option)</b>	The calculation in accordance with ASME PTC 19.3 TW-2016 of individual thermowells minimises the risk of dynamic damage that can be caused by the vortex shedding of a Kármán vortex street (Vortex Induced Vibration; VIV). In addition, the static loads due to lateral flow and the process pressure are calculated depending on the temperature. The calculation can be carried out independently using an online tool or as a WIKA engineered service (subject to charges).  → For further information, see Technical information IN 00.15 "Wake frequency calculation".

dann

## Certificates (option)

Certificates	
<b>Certificates</b>	<ul style="list-style-type: none"> <li>■ 2.2 test report</li> <li>■ 3.1 inspection certificate</li> </ul>

Approvals and certificates, see website

## Dimensions in mm [in]

### Design TW30-A

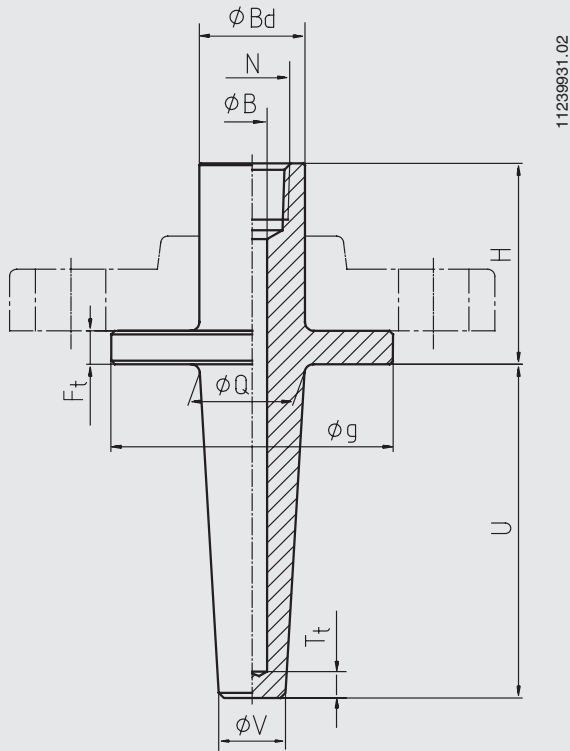

#### Legend:

- H Connection length
- U Insertion length
- N Connection to thermometer
- Ø B Bore size
- Ø Q Root diameter
- Ø V Tip diameter
- Ø Bd Bar diameter
- Ø g Sealing face diameter
- T<sub>t</sub> Tip thickness (6.4 mm [0.25 in])
- F<sub>t</sub> Sealing face thickness (9.5 mm [0.37 in])

Flange is not included in the standard scope of delivery

### Tapered thermowell form, design TW30-A

Lap flange		Dimensions in mm [in]						Weight in kg [lbs]		
DN	PN in lbs	H	Ø Q	Ø V	Ø B	Ø Bd	Ø g	U = 4 in	U = 13 in	U = 22 in
1"	150	2 ¼ in [approx. 57 mm]	19 [0.750]	16 [0.625]	■ 6.6 [0.260] ■ 8.5 [0.355]	33.4 [1.315]	51 [2.008]	1.1 [2.425]	1.6 [3.527]	2.1 [4.629]
	300	2 ¼ in [approx. 57 mm]	19 [0.750]	16 [0.625]	■ 6.6 [0.260] ■ 8.5 [0.355]	33.4 [1.315]	51 [2.008]	1.1 [2.425]	1.6 [3.527]	2.1 [4.629]
	600	2 ¼ in [approx. 57 mm]	19 [0.750]	16 [0.625]	■ 6.6 [0.260] ■ 8.5 [0.355]	33.4 [1.315]	51 [2.008]	1.1 [2.425]	1.6 [3.527]	2.1 [4.629]
	1,500	3 ¼ in [approx. 83 mm]	19 [0.750]	16 [0.625]	■ 6.6 [0.260] ■ 8.5 [0.355]	33.4 [1.315]	51 [2.008]	1.1 [2.425]	1.6 [3.527]	2.1 [4.629]
	2,500	3 ¼ in [approx. 83 mm]	19 [0.750]	16 [0.625]	■ 6.6 [0.260] ■ 8.5 [0.355]	33.4 [1.315]	51 [2.008]	1.1 [2.425]	1.6 [3.527]	2.1 [4.629]
1 ½"	150	2 ¼ in [approx. 57 mm]	27 [1.063]	19 [0.750]	■ 6.6 [0.260] ■ 8.5 [0.355]	48.3 [1.902]	73 [2.874]	1.8 [3.968]	2.5 [5.512]	3.3 [7.275]
	300	2 ¼ in [approx. 57 mm]	27 [1.063]	19 [0.750]	■ 6.6 [0.260] ■ 8.5 [0.355]	48.3 [1.902]	73 [2.874]	1.8 [3.968]	2.5 [5.512]	3.3 [7.275]
	600	2 ¼ in [approx. 57 mm]	27 [1.063]	19 [0.750]	■ 6.6 [0.260] ■ 8.5 [0.355]	48.3 [1.902]	73 [2.874]	1.8 [3.968]	2.5 [5.512]	3.3 [7.275]
	1,500	3 ¼ in [approx. 83 mm]	27 [1.063]	19 [0.750]	■ 6.6 [0.260] ■ 8.5 [0.355]	48.3 [1.902]	73 [2.874]	1.8 [3.968]	2.5 [5.512]	3.3 [7.275]
	2,500	3 ¼ in [approx. 83 mm]	27 [1.063]	19 [0.750]	■ 6.6 [0.260] ■ 8.5 [0.355]	48.3 [1.902]	73 [2.874]	1.8 [3.968]	2.5 [5.512]	3.3 [7.275]

2"	150	2 ¼ in [approx. 57 mm]	27 [1.063]	19 [0.750]	■ 6.6 [0.260] ■ 8.5 [0.355]	60.3 [2.374]	92 [3.622]	2.7 [5.952]	3.4 [7.496]	4.1 [9.039]
	300	2 ¼ in [approx. 57 mm]	27 [1.063]	19 [0.750]	■ 6.6 [0.260] ■ 8.5 [0.355]	60.3 [2.374]	92 [3.622]	2.7 [5.952]	3.4 [7.496]	4.1 [9.039]
	600	3 ¼ in [approx. 83 mm]	27 [1.063]	19 [0.750]	■ 6.6 [0.260] ■ 8.5 [0.355]	60.3 [2.374]	92 [3.622]	2.7 [5.952]	3.4 [7.496]	4.1 [9.039]
	1,500	3 ¼ in [approx. 83 mm]	27 [1.063]	19 [0.750]	■ 6.6 [0.260] ■ 8.5 [0.355]	60.3 [2.374]	92 [3.622]	2.7 [5.952]	3.4 [7.496]	4.1 [9.039]
	1,500	3 ¼ in [approx. 83 mm]	27 [1.063]	19 [0.750]	■ 6.6 [0.260] ■ 8.5 [0.355]	60.3 [2.374]	92 [3.622]	2.7 [5.952]	3.4 [7.496]	4.1 [9.039]

### Ordering information

Model / Thermowell form / Thermowell material / Connection to thermometer / Wall thickness of flange nozzle / Bore size  $\varnothing B$  / Nominal width DN / Pressure rating PN / Insertion length U / Connection length H / Bar diameter  $\varnothing Bd$  / Root diameter  $\varnothing Q$  / Tip diameter  $\varnothing V$  / Assembly with thermometer / Certificates / Options

© 12/2007 WIKA Alexander Wiegand SE & Co. KG, all rights reserved.  
The specifications given in this document represent the state of engineering at the time of publishing.  
We reserve the right to make modifications to the specifications and materials.



**WIKA Alexander Wiegand SE & Co. KG**  
Alexander-Wiegand-Straße 30  
63911 Klingenberg/Germany  
Tel. +49 9372 132-0  
info@wika.de  
www.wika.de