

Magnetostrictive level transmitter

Version with local indication

Models FLM-TB and FLM-TH

WIKA data sheet LM 20.10



For approvals, see
page 4

Applications

- High-accuracy level detection for almost all liquid media in the process industry
- Suitable for interface layer applications or processes with heavy foaming
- Chemical, petrochemical industry, natural gas, offshore, shipbuilding, power generating equipment, power plants

Special features

- Insertion length 100 ... 6,000 mm [3.94 ... 236.22 in] (flexible version up to 22,000 mm [866.14 in])
- Version with LC display for local indication of the level (optionally with heatable LC display for lower ambient temperatures)
- High accuracy of up to ± 0.2 mm [0.008 in] or ± 0.01 % over the entire measuring range
- Very high resolution of < 0.1 mm [0.004 in]
- Version for hazardous areas



Level transmitter with LC display, model FLM-TB

Description

The model FLM-TB magnetostrictive level transmitter is used for high-accuracy, continuous level detection of liquids, also with long insertion lengths.

The model FLM-TB has a local LC display. For particularly low ambient temperatures, the model FLM-TH version can be used, which has a heated LC display.

Furthermore, the model FLM-TB and FLM-TH level transmitters with LC display are available as both an intrinsically safe version and a version with flameproof enclosure.

Specifications

Functionality

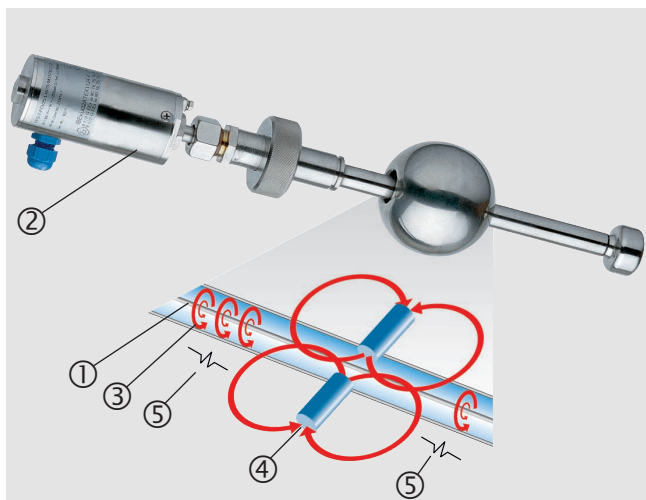

- ① Wire
- ② Sensor housing
- ③ Magnetic field
- ④ Permanent magnet
- ⑤ Torsional wave

Design and operating principle



- The measurement process is triggered by a current impulse. This current produces a circular magnetic field ③ along a wire ① made of magnetostrictive material which is held under tension inside the corrugated tube.
- At the point being measured (liquid level) there is a float with permanent magnets ④ acting as a position transducer.
- The superposition of these two magnetic fields triggers a mechanical torsional wave ⑤ in the wire.
- This is converted into an electrical signal at the end of the wire in the sensor housing ② by a piezoceramic converter.
- The measured propagation delay enables the origination point of the mechanical wave, and thus the float position, to be determined with high accuracy.

Overview of versions



Model	Display	Electrical connection	Ex version
FLM-TB	LC display	Cable gland	-
FLM-TBI	LC display	Cable gland	Ex ia
FLM-TBD	LC display	Cable gland	Ex ia/db
FLM-TH	LC display with integrated heating	Cable gland	-
FLM-THI	LC display with integrated heating	Cable gland	Ex ia
FLM-THD	LC display with integrated heating	Cable gland	Ex ia/db

Basic information		
Connection housing		
Material	Stainless steel 1.4404 (316L), safety glass	
Sensor tube		
Material	Stainless steel 1.4571 (316Ti) Further materials such as Hastelloy on request	
Diameter	12 mm [0.47 in]	
Insertion length	Rigid version	100 ... 6,000 mm [3.937 ... 236.221 in]
	Flexible version (with corrugated tube)	1,500 ... 22,000 mm [59.055 ... 866.142 in]
Accuracy specifications		
Level	Up to ± 0.2 mm [0.008 in] or ± 0.01 %	
Resolution (HART®)	0.1 mm [0.004 in]	
Process connection		
Thread size	Mounting thread	<ul style="list-style-type: none"> ■ G ½ ... G 2" ■ ½ NPT ... 2 NPT
	Mounting flange	<ul style="list-style-type: none"> ■ DIN EN DN 50 ... DN 200, PN 6 ... PN 100 ■ ANSI 2 ... 8", Class 150 ... 600
	Height-adjustable bite-type fitting	
	→ Further thread sizes on request	
Output signal	4 ... 20 mA (3.8 ... 20.5 mA) / HART® version 6	
Residual current	3.6 mA or 21.5 mA (adjustable)	
Electrical connection		
Connection type	2-wire	
Cable diameter	5 ... 10 mm [0.2 ... 0.39 in]	
Supply voltage	Standard (non-Ex)	DC 12 ... 50 V
	Intrinsically safe version (Ex ia)	DC 12 ... 30 V
	Flameproof version (Ex db)	DC 12 ... 50 V
	Heating (model FLM-TH)	DC 24 V (± 10 %)
Electrical output	<ul style="list-style-type: none"> ■ Cable bushing M20 x 1.5 ■ Cable gland M20 x 1.5 ■ ½ NPT thread for conduit wiring 	
Operating conditions		
Ambient temperature range	FLM-TB	-40 ... +85 °C [-40 ... 185 °F]
	FLM-TH	-55 ... +85 °C [-67 ... 185 °F] (with integrated heating)
Storage temperature range	-40 ... +85 °C [-40 ... +185 °F]	
Process temperature	Standard temperature	-40 ... +85 °C [-40 ... 185 °F]
	Normal temperature (NT)	-40 ... +125 °C [-40 ... 257 °F]
	High temperature (HT)	-40 ... +250 °C [-40 ... 482 °F]
	Highest temperature (HHT)	-40 ... +450 °C [-40 ... 842 °F]
	Low temperature (LT)	-65 ... +125 °C [-40 ... 257 °F]
Other versions	<ul style="list-style-type: none"> ■ Interface measurement, with two floats ■ Temperature sensors 	

Approvals

Logo	Description	Region
	EU declaration of conformity	European Union
	EMC directive EN 61326 emission (group 1, class B) and immunity (industrial environments)	
	RoHS directive	
	UKCA	United Kingdom
	Electromagnetic compatibility regulations	
	Restriction of Hazardous Substances (RoHS) regulations	

Optional approvals

Logo	Description	Region
	EU declaration of conformity	European Union
	ATEX directive Hazardous areas - Ex i Zone 0 gas II 1G Ex ia IIC T6 ... T1 Ga Zone 0/1 gas II 1/2G Ex ia IIC T6 ... T1 Ga/Gb Zone 1 gas II 2G Ex ia IIC T6 ... T1 Gb Zone 1 dust II 2D Ex ia IIIC TX °C Db (see thermal data on approval certificate) - Ex db Zone 0/1 gas II 1/2G Ex ia/db IIC T6 ... T1 Ga/Gb Zone 1 gas II 2G Ex db ia IIC T6 ... T1 Gb Zone 1 dust II 2D Ex ia tb IIIC TX °C Db (see thermal data on approval certificate)	
	IECEX	International
	Hazardous areas - Ex ia Zone 0 gas Ex ia IIC T6 ... T1 Ga Zone 0/1 gas Ex ia IIC T6 ... T1 Ga/Gb Zone 1 gas Ex ia IIC T6 ... T1 Gb Zone 1 dust Ex ia IIIC TX °C Db (see thermal data on approval certificate) - Ex db Zone 0/1 gas Ex ia/db IIC T6 ... T1 Ga/Gb Zone 1 gas Ex db ia IIC T6 ... T1 Gb Zone 1 dust Ex ia tb IIIC TX °C Db (see thermal data on approval certificate)	

Manufacturer's information and certificates

Logo	Description
	SIL 2 Functional safety
-	China RoHS directive

Certificates

Certificates	
Certificates	<ul style="list-style-type: none"> ■ 2.2 test report per EN 10204 (e.g. state-of-the-art manufacturing, material proof, indication accuracy) ■ 3.1 inspection certificate per EN 10204 (e.g. material proof for wetted metal parts, indication accuracy, calibration certificate)

→ For approvals and certificates, see website

Dimensions in mm [in]

Version with process connection flange

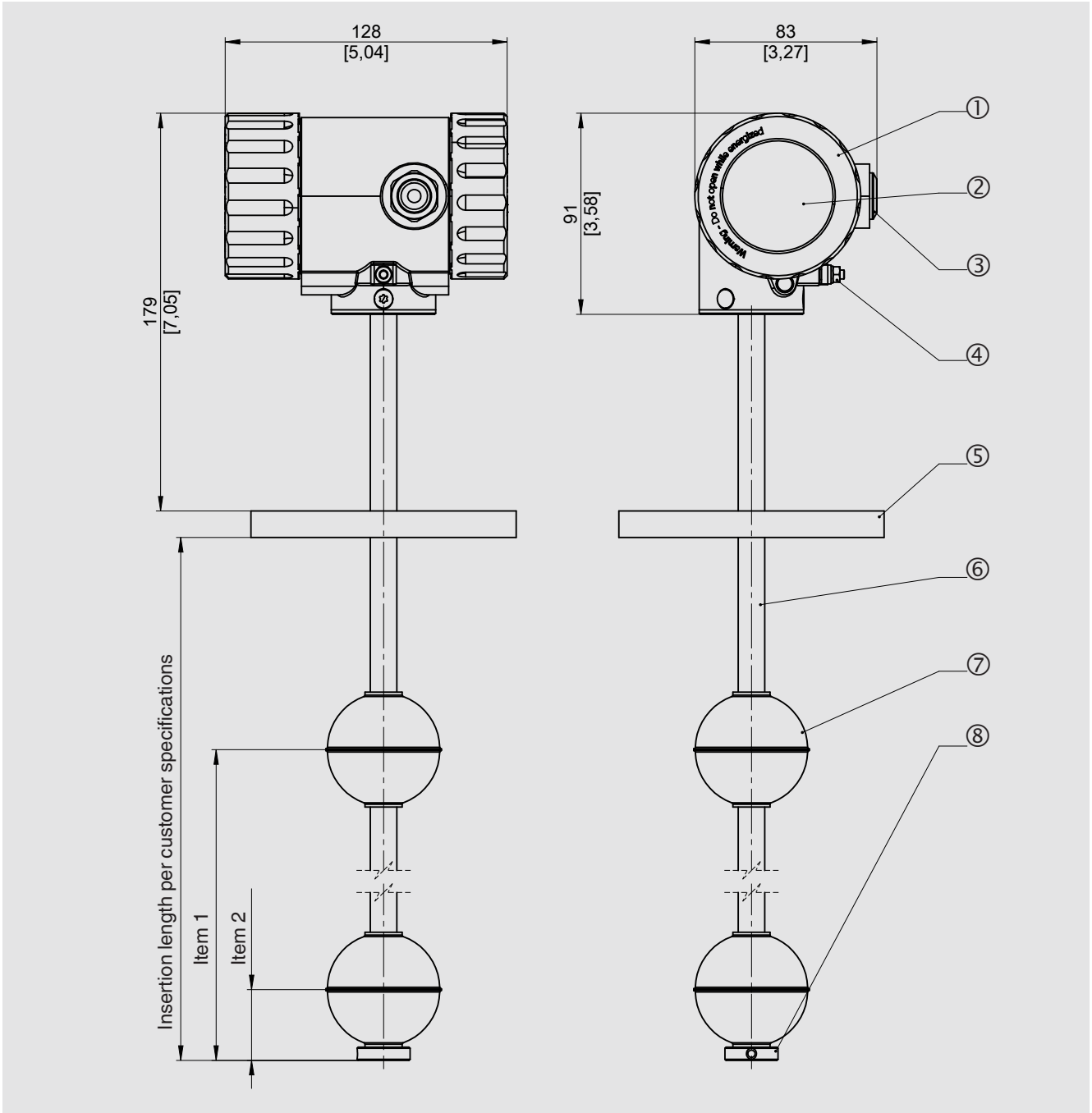

- ① Probe head
- ② Display unit
- ③ Plug screw M20 x 1.5
- ④ Ground connection
- ⑤ Flange per customer specifications
- ⑥ Probe tube Ø12
- ⑦ Float
- ⑧ Adjusting collar, can be dismantled

Version with mounting thread

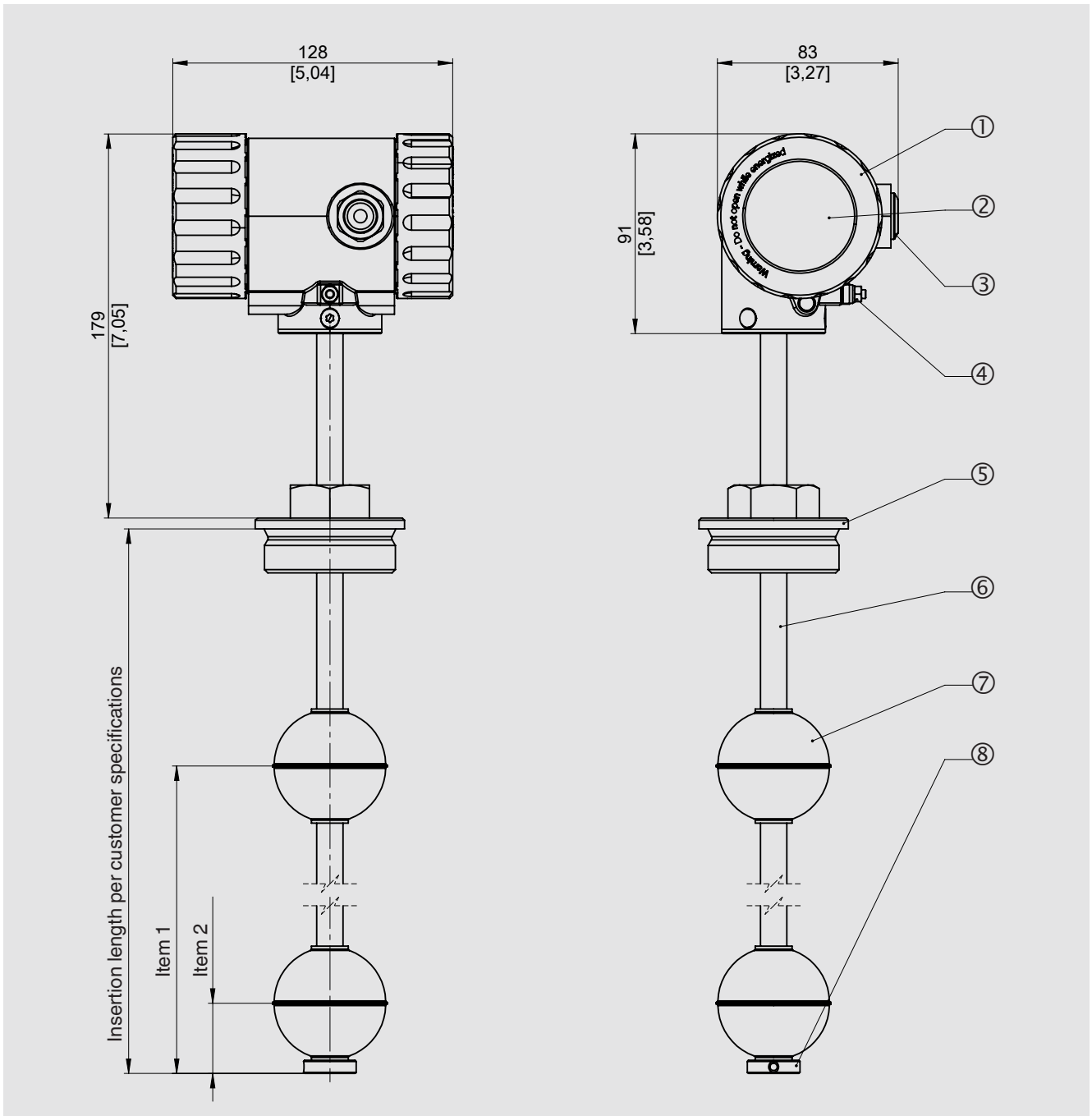

- ① Probe head
- ② Display unit
- ③ Plug screw M20 x 1.5
- ④ Ground connection
- ⑤ Mounting thread per customer specifications
- ⑥ Probe tube Ø12
- ⑦ Float
- ⑧ Adjusting collar, can be dismantled

Spherical float

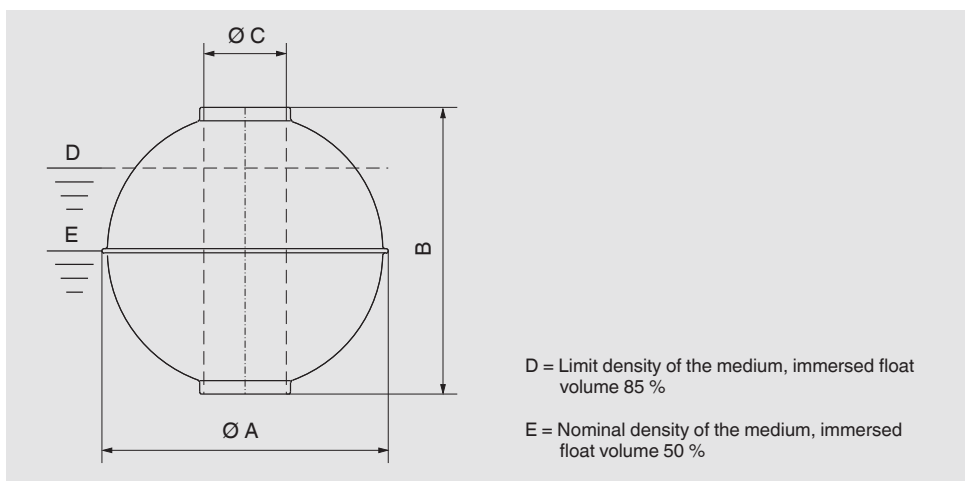

Material	Version	Suitable for guide tube Ø in mm [in]	Ø A in mm [in]	B in mm [in]	Ø C in mm [in]	Max. operating pressure in bar [psi]	Max. operating temp. in °C [°F]	Limit density 85 % in kg/m ³ [lb/ft ³]
Stainless steel 316Ti	V52A	14 [0.55]	52 [2.05]	52 [2.05]	15 [0.59]	40 [580.15]	250 [482]	720 [44.95]
	V62A	14 [0.55]	62 [2.44]	61 [2.4]	15 [0.59]	32 [464.12]	250 [482]	597 [37.27]
	V83A	14 [0.55]	83 [3.27]	81 [3.19]	15 [0.59]	25 [362.59]	250 [482]	430 [26.84]
	V80A	18 [0.71]	80 [3.15]	76 [2.99]	23 [0.91]	25 [362.59]	250 [482]	660 [41.2]
	V98A	18 [0.71]	98 [3.86]	96 [3.78]	23 [0.91]	25 [362.59]	250 [482]	597 [37.27]
	V105A	18 [0.71]	105 [4.13]	103 [4.06]	23 [0.91]	25 [362.59]	250 [482]	533 [33.27]
	V120A	18 [0.71]	120 [4.72]	117 [4.61]	23 [0.91]	25 [362.59]	250 [482]	389 [24.28]
	V120/38A	18 [0.71]	120 [4.72]	116 [4.57]	38 [1.5]	25 [362.59]	250 [482]	537 [33.52]
Titanium 3.7035 (grade 2)	T52A	14 [0.55]	52 [2.05]	52 [2.05]	15 [0.59]	25 [362.59]	250 [482]	570 [35.58]
	T62A	14 [0.55]	62 [2.44]	62 [2.44]	15 [0.59]	25 [362.59]	250 [482]	505 [31.53]
	T83A	14 [0.55]	83 [3.27]	81 [3.19]	15 [0.59]	25 [362.59]	250 [482]	350 [21.85]
	T80A	18 [0.71]	80 [3.15]	76 [3.0]	23 [0.91]	25 [362.59]	250 [482]	665 [41.51]
	T98A	18 [0.71]	98 [3.86]	96 [3.78]	23 [0.91]	25 [362.59]	250 [482]	495 [30.9]
	T105A	18 [0.71]	105 [4.13]	103 [4.06]	23 [0.91]	25 [362.59]	250 [482]	369 [23.04]
	T120A	18 [0.71]	120 [4.72]	117 [4.61]	23 [0.91]	25 [362.59]	250 [482]	329 [20.54]

Special floats for higher temperature and pressure ranges are available on request.

Note: The optimum float will be selected after an application test carried out by WIKA.

Cylindrical float

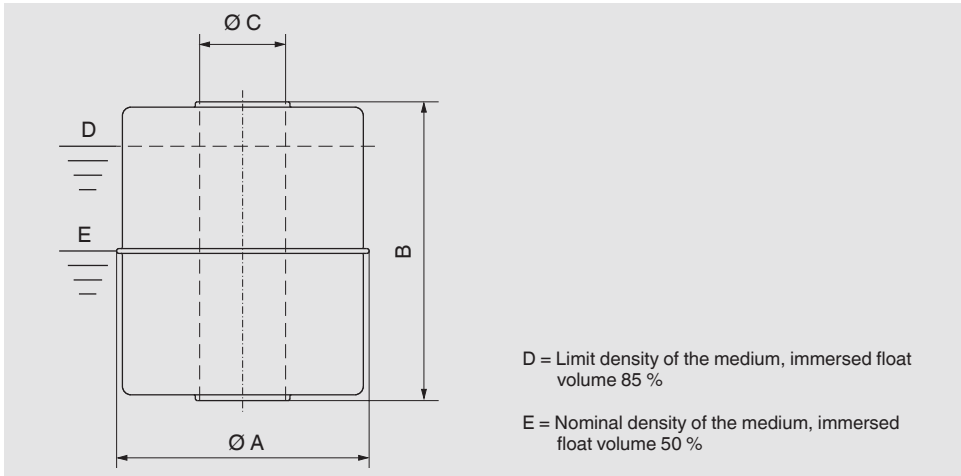

Material	Version	Suitable for guide tube Ø in mm [in]	Ø A in mm [in]	B in mm [in]	Ø C in mm [in]	Max. operating pressure in bar [psi]	Max. operating temp. in °C [°F]	Limit density 85 % in kg/m ³ [lb/ft ³]
Stainless steel 316Ti	V44A	14 [0.55]	44 [1.73]	52 [2.05]	15 [0.59]	16 [232.06]	250 [482]	818 [51.07]
	V44A	14 [0.55]	44 [1.73]	52 [2.05]	15 [0.59]	25 [362.59]	200 [392]	800 [49.94]
Titanium 3.7035 (grade 2)	T44A	14 [0.55]	44 [1.73]	52 [2.05]	15 [0.59]	16 [232.06]	250 [482]	550 [34.34]
PVC	P55A	16 [0.63]	55 [2.17]	54 [2.13]	22 [0.87]	3 [43.51]	60 [140]	798 [49.82]
	P80A	20 [0.79]	80 [3.15]	79 [3.11]	25 [0.98]	3 [43.51]	60 [140]	573 [35.77]
Polypropylene	PP55A	16 [0.63]	55 [2.17]	54 [2.13]	22 [0.87]	3 [43.51]	80 [176]	595 [37.14]
	PP80A	20 [0.79]	80 [3.15]	79 [3.11]	25 [0.98]	3 [43.51]	80 [176]	431 [26.91]
PVDF	PF55A	16 [0.63]	55 [2.17]	69 [2.72]	22 [0.87]	3 [43.51]	100 [212]	821 [51.25]
	PF80A	20 [0.79]	80 [3.15]	79 [3.11]	25 [0.98]	3 [43.51]	100 [212]	681 [42.51]

Special floats for higher temperature and pressure ranges are available on request.

Note: The optimum float will be selected after an application test carried out by WIKA.

Ordering information

Model / Version / Electrical connection / Process connection / Guide tube diameter / Guide tube length L / 100 % mark L1 / Measuring range M (span 0 ... 100 %) / Process specifications (operating temperature and pressure, limit density) / Options

© 12/2024 WIKA Alexander Wiegand SE & Co. KG, all rights reserved.
The specifications given in this document represent the state of engineering at the time of publishing.
We reserve the right to make modifications to the specifications and materials.
In case of a different interpretation of the translated and the English data sheet, the English wording shall prevail.

