

Monoblock

For sampling and injection processes

Models IBS3 and IBJ4

WIKA data sheet AC 09.26



For further approvals
see page 7

Applications

- Oil and gas industry, chemical and petrochemical industries, power plants and water/wastewater industries
- For gaseous and liquid, aggressive and highly viscous or contaminated media, also in aggressive environments
- Chemical dosing, gas dehydration, methanol injection, pipe corrosion prevention or water treatment
- Process media sampling for analysing systems (e.g. gas chromatographs, dew point analysers)

Special features

- Increased safety with metal enclosed valve seats and double valve body seal
- High-quality machining guarantees smooth operation with low torque and low wear
- Leak-tested tightness in accordance with BS6755 / ISO 5208 leakage rate A
- Customisable arrangement with ball and needle valves
- Customer-specific combination of valves and instruments (hook-up) on request

Description

The monoblock with probe for sampling and injection processes has been designed to meet the requirements of the process industry. It is especially well suited to applications in natural gas and aggressive media. The compact design integrates two shut-off valves to separate the process from the instrument side.

The modular monoblock design allows using an arrangement of ball valves and/or needle valves. Injection valves have also an integrated non-return valve to prevent bi-directional flow. The integral probe is solidly attached to the valve and it is designed according to the flow condition in the pipeline.



Fig. left: Model IBS3, for sampling processes
Fig. right: Model IBJ4, for injection processes

Configurator



Standard articles



The valve seat design and the redundant seals of the valve body ensure high durability and tightness. In case the soft valve seat fails, the metal-to-metal seat will ensure that the valve can still be operated and set to a safe position. The tightness is guaranteed for the connection between the process and the measuring instrument and towards the atmosphere.

The super-finished machining of the internal parts allows a very smooth and precise operation, even at high pressures and after long periods without valve operation. The surface finish is also minimising corrosion with aggressive media and makes it easier to clean.

Specifications

Monoblock, models IBS3 and IBJ4	
Standards used	
Design	<ul style="list-style-type: none"> ■ EEMUA publication 182, specification for integral block-and-bleed valve manifolds ■ ASME B16.34, valves - flanged, threaded and welding end ■ ASME BPVC section VIII, rules for construction of pressure vessels division 1 ■ ASME B31.1, power piping ■ ASME B31.3, process piping ■ ISO 17292, metal ball valves for petroleum, petrochemical and allied industries ■ MSS SP-99, valves for measuring instruments ■ ASME B16.5, pipe flanges and flange fittings ■ ASME B1.20.1, pipe threads, general purpose (inch)
Tests	<ul style="list-style-type: none"> ■ API 598, valve inspection and testing ■ ISO 5208, pressure testing of metallic valves with leakage rate A ■ MSS SP-61, pressure testing of valves ■ DIN EN 12266-1, pressure tests, test procedures and acceptance criteria for industrial valves ■ API607/API6FA/ISO 10497 fire test for valves
Material requirements	<ul style="list-style-type: none"> ■ NACE MR0175 / ISO 15156, use in H₂S-containing environments in oil and gas production ■ Norsok M-630, specification for use in pipelines (Norway)
Marking	ASME B16.34, valves - flanged, threaded and welding end
Pressure-temperature limits (for diagram, see page 5)	The limits for operating pressure and temperature depend on the sealing material
Function (for functional principle, see next page)	<ul style="list-style-type: none"> ■ Model IBS3 for sampling processes Double block and bleed (2 x shut off and 1 x vent) ■ Model IBJ4 for injection processes Double block and bleed with non-return valve (1 x non-return, 2 x shut off and 1 x vent)
Arrangement (for valve types, see next page)	The shut-off valve(s) and the vent valve can be defined individually as ball valve or needle valve.
Pressure inlet / outlet connection	<ul style="list-style-type: none"> ■ ½ NPT female ■ G ½ female ■ Other connections on request
Process connection	<ul style="list-style-type: none"> ■ Flange 1" ... 2" / class 150 ... class 2500, per ASME B16.5 ■ Other flanges on request
Sampling probe/injection quill	½" schedule 160, per ASME B36.10 Nominal pipe size: DN 15 (outer diameter x wall thickness 21.3 x 4.78 mm) Insertion length: 150 ... 500 mm. Versions with support collars on request. Pipe end: Cut under 45°
Surface roughness Ra of the sealing face	Following ASME B16.5 <ul style="list-style-type: none"> ■ RF: 3.2 ... 6.3 µm [125 ... 250 µin] (spiral surface) ■ RJ: 1.6 µm [63 µin]
Vent connection	½ NPT female or ¼ NPT female, plug screw is included in delivery, though not pre-fitted.

Functional diagram

Model IBS3

Double block and bleed
(2 x shut off and 1 x vent)

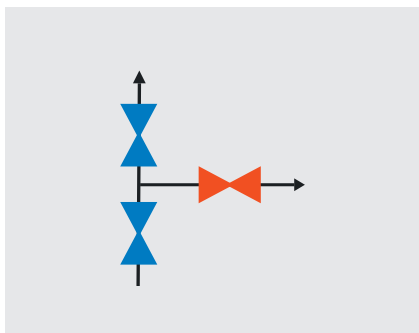

Model IBJ4

Double block and bleed
(1 x non-return, 2 x shut off and 1 x vent)

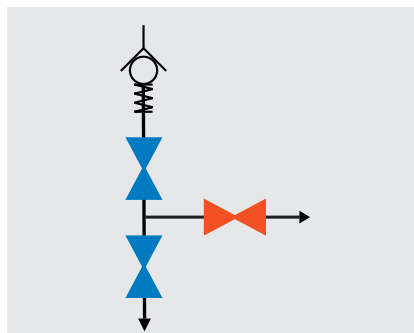

Colour code Blue: Shut off
 Red: Vent

Functional principle

Model IBS3, for sampling processes

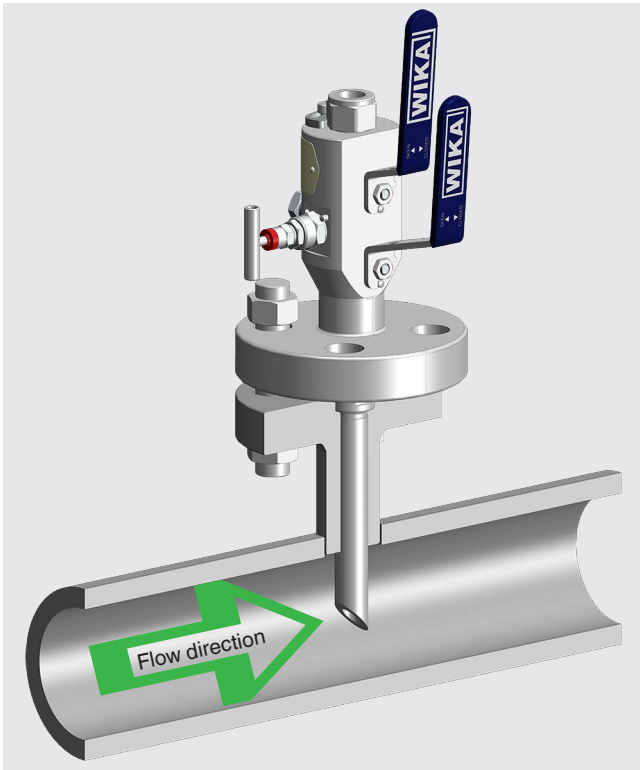

The monoblock for sampling processes has been designed to extract a fluid from a pressurised system. The sampling probe allows to extract sample media for analysis.

The fluid is typically sampled from or injected to the center of the pipeline. The pipe of the sampling probe/injection quill has to be run through the nozzle and reaches out to the middle of the process pipe. The flange and pipe are jointed to one piece to ensure a solid and leakage-free integration. Depending on the material, the pipe for the sampling probe/injection quill is made of bar material.

WIKA provides support collars and is able to perform wake frequency calculations on request. For more detailed information, see Technical information IN 00.15.

Model IBJ4, for injection processes

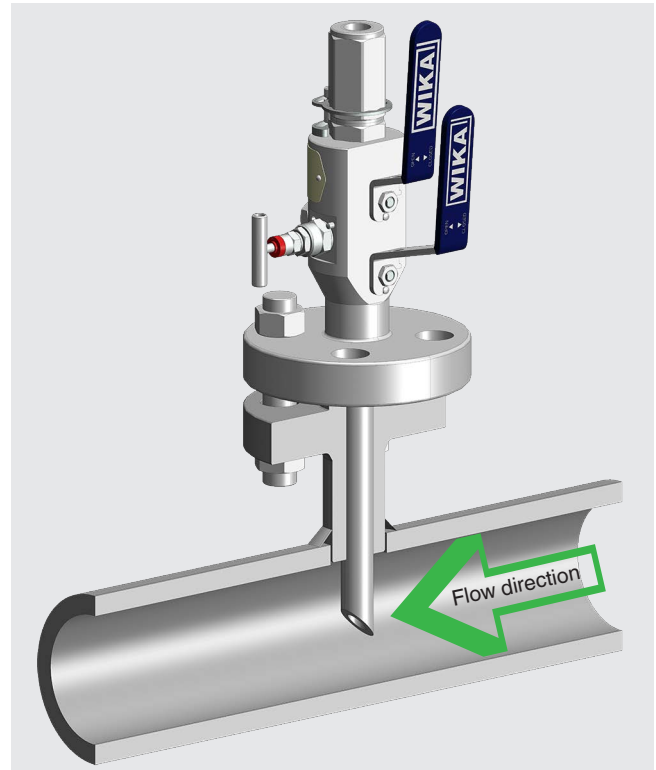

The monoblock for injection processes has been designed to enter a fluid through an injection quill into a pressurized system. The model IBJ4 is always equipped with a non-return valve to prevent backflow.

Non-return valve (only for model IBJ)

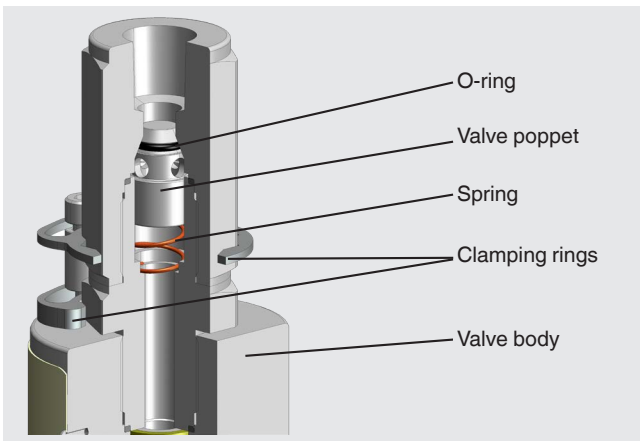

Materials	
Wetted parts	
Valve body	<ul style="list-style-type: none"> ■ Stainless steel 316/316L (1.4401/1.4404) ■ Duplex F51 (1.4462) ■ Super Duplex F55 (1.4501) ■ Hastelloy C276 (2.4819) ■ Monel 400 (2.4360) ■ Carbon steel ASTM A350 LF2, class 2 ¹⁾
Sampling probe/injection quill, valve fittings, ball, valve seats, valve stem, bonnet body, spindle tip	<ul style="list-style-type: none"> ■ Stainless steel 316/316L (1.4401/1.4404) ■ Duplex F51 (1.4462) ■ Super Duplex F55 (1.4501) ■ Hastelloy C276 (2.4819) ■ Monel 400 (2.4360)
Sealing	<ul style="list-style-type: none"> ■ PEEK (ball valve seat) ■ RTFE (ball valve seat) ■ Graphite (needle valve sealing packing) ■ PTFE (needle valve sealing packing)
Non-wetted parts	
Handle, bonnet, valve spindle, locking plate, locking pin, product label, screws	Stainless steel
Handle grip	PVC

¹⁾ Valve body from carbon steel ASTM A350 LF2, the other wetted parts from stainless steel 316/316L (1.4401/1.4404). Unpainted carbon steel valves have an oil finish for corrosion protection during storage. This is not a substitute for paint or other protective coating to be applied at the place of use.

Other materials on request

Valve type

Ball valve

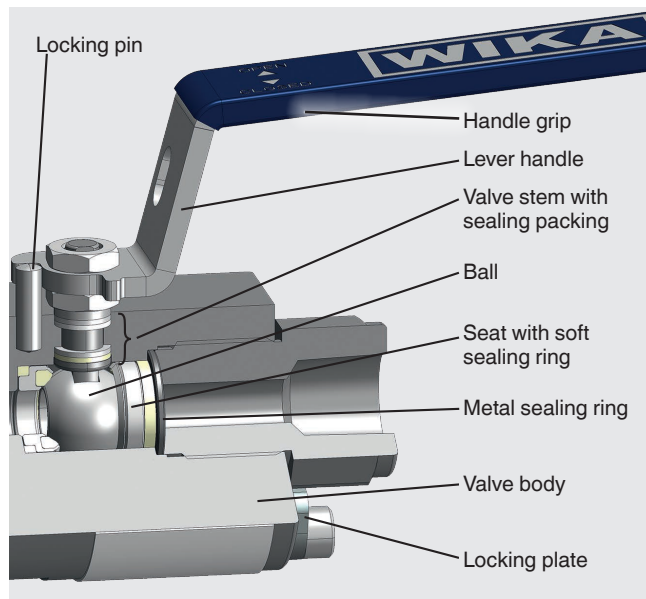

Needle valve

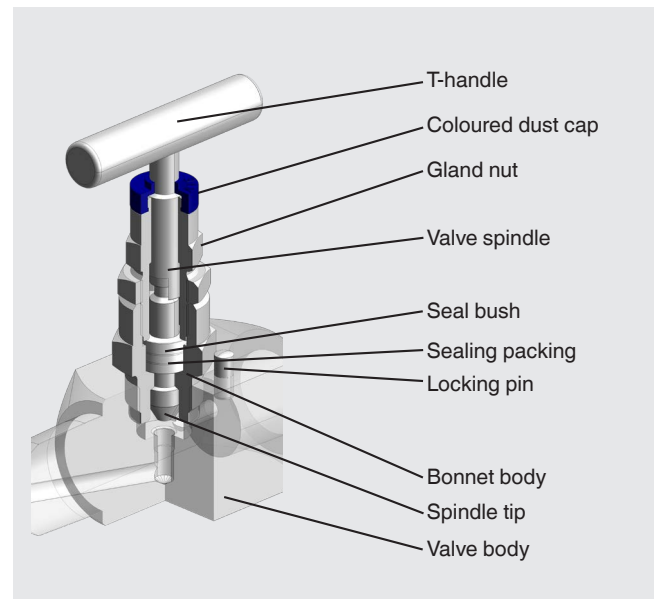

Specification	Ball valve	Needle valve
Design	<ul style="list-style-type: none"> ■ Antistatic design ■ Blow-out-safe valve stem ■ Self-relieving valve seats 	<ul style="list-style-type: none"> ■ Non-rotating spindle tip ■ Blow-out-safe spindle tip ■ Back seat design ■ Metal-to-metal seat
Colour code	Blue: Shut off Red: Vent	
Valve bore size	10 mm [0.394 in]	5 mm [0.197 in]

Options for ball valve

Anti-tamper version with padlock

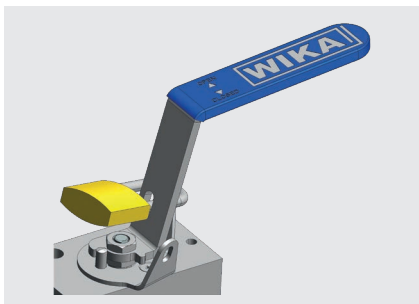

Extended lever handle



Options for needle valve

Anti-tamper version



Anti-tamper key



Anti-tamper version with padlock

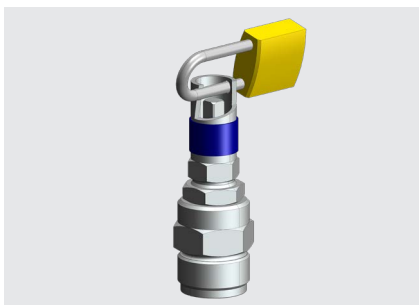

Extended lever handle



Pressure-temperature diagram

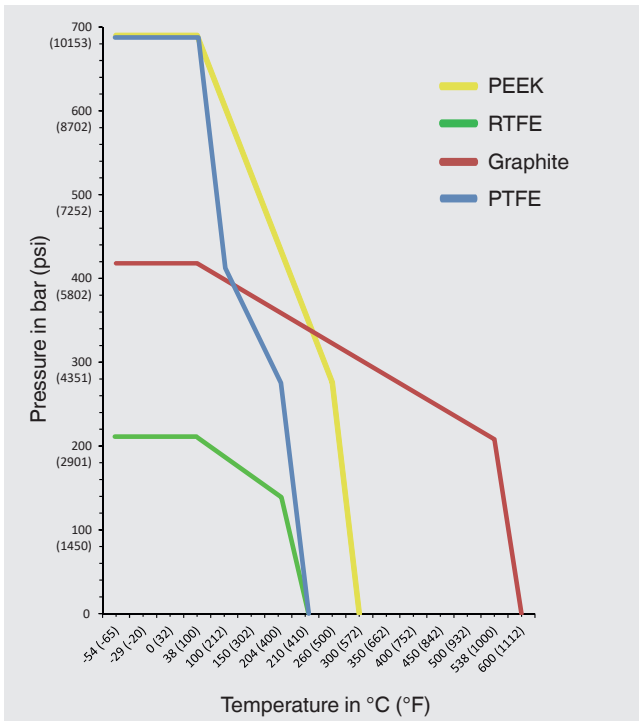

	Sealing material	Max. permissible operating pressure in bar at temperature in °C	Max. permissible operating pressure in psi at temperature in °F
Ball valve seat	PEEK ¹⁾	690 bar at 38 °C	10,000 psi at 100 °F
		276 bar at 250 °C	4,000 psi at 480 °F
	RTFE ²⁾	210 bar at 38 °C	3,000 psi at 100 °F
		138 bar at 204 °C	2,000 psi at 400 °F
Needle valve sealing packing	Graphite	420 bar at 38 °C	6,000 psi at 100 °F
		209 bar at 538 °C	3,030 psi at 1,000 °F
	PTFE	690 bar at 38 °C	10,000 psi at 100 °F
		276 bar at 204 °C	4,000 psi at 400 °F

1) Polyetheretherketone

2) Reinforced PTFE

The minimum design temperature is -54 °C [-65 °F]. For permanently low operating temperatures of ≤ -54 °C [≤ -65 °F] a special design is required.

Approvals

Logo	Description	Country
	EAC (option) Machinery directive	Eurasian Economic Community

Manufacturer's information and certificates

Description
PMI ¹⁾ test certificate (option) All wetted parts
Type tested for fire safety in accordance with API 607, ISO 10497, BS 6755-2 ²⁾

- 1) Positive material identification
2) Only for ball valve

Certificates

- 3.1 inspection certificate per EN 10204 (option)
- Material certificate for all wetted parts per NACE MR0103/MR0175
- Confirmation of pressure tests per API 598 ³⁾

- 3) Shell test: 15 s test duration with 1.5 times the permissible working air pressure
Seat test: 15 s test duration with 6 bar air/nitrogen



© 12/2019 WIKA Alexander Wiegand SE & Co. KG, all rights reserved.
The specifications given in this document represent the state of engineering at the time of publishing.
We reserve the right to make modifications to the specifications and materials.
In case of a different interpretation of the translated and the English data sheet, the English wording shall prevail.

