

Monoblock

With threaded connection

Models IBM2 and IBM3

WIKA data sheet AC 09.24



For further approvals
see page 10

Applications

- Oil and gas industry, chemical and petrochemical industries, power plants, shipbuilding
- For gaseous and liquid aggressive media that are highly viscous or crystallising, also in aggressive environments
- Test benches and calibration equipment
- Control panels (e. g. wellheads, actuators), lubrication systems, dry gas seal systems
- Sampling systems for process analysis

Special features

- Increased safety with metal enclosed valve seats and double valve body seal
- High-quality machining guarantees smooth operation with low torque and low wear
- Leak-tested tightness in accordance with BS 6755 / ISO 5208 leakage rate A
- Customisable arrangement with ball and needle valves
- Customer-specific combination of valves and instruments (hook-up) on request

Description

The monoblock has been designed specifically to fit into the small space of control panel and valve battery installations.

With its very compact dimensions, the monoblock can be used in a wide range of applications providing high overpressure safety within a large spectrum of temperature ranges. The modular monoblock design allows using an arrangement of ball valves and/or needle valves in the same valve body.

For applications with liquid or dirty media, ball valves are recommended due to easy cleaning of the straight-through internal bore.

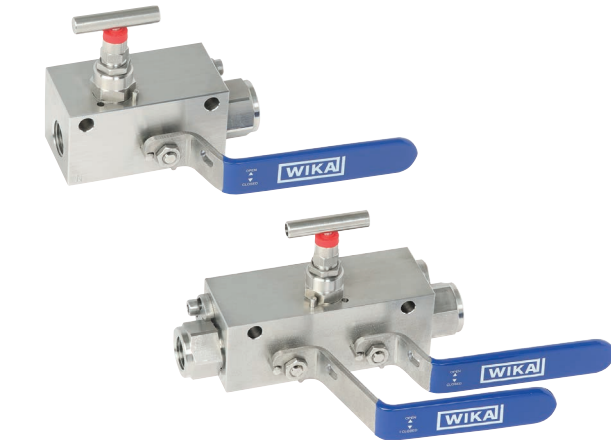

Fig. left: Model IBM2, block-and-bleed valve manifold
Fig. right: Model IBM3, double block-and-bleed valve manifold

Configurator



Standard articles



The valve seat design and the redundant seals of the valve body ensure high durability and tightness. In case the soft valve seat fails, the metal-to-metal seat will ensure that the valve can still be operated and set to a safe position. The tightness is guaranteed for the connection between the process and the measuring instrument and towards the atmosphere.

The super-finished machining of the internal parts allows a very smooth and precise operation, even at high pressures and after long periods without valve operation. The surface finish is also minimising corrosion with aggressive media and makes it easier to clean.

Specifications

Monoblock, models IBM2 and IBM3

Standards used

Design	<ul style="list-style-type: none"> ■ EEMUA publication 182, specification for integral block-and-bleed valve manifolds ■ ASME B16.34, valves - flanged, threaded and welding end ■ ASME BPVC section VIII, rules for construction of pressure vessels division 1 ■ ASME B31.1, power piping ■ ASME B31.3, process piping ■ ISO 17292, metal ball valves for petroleum, petrochemical and allied industries ■ MSS SP-99, valves for measuring instruments ■ ASME B16.5, pipe flanges and flange fittings ■ ASME B1.20.1, pipe threads, general purpose (inch)
Tests	<ul style="list-style-type: none"> ■ API 598, valve inspection and testing ■ ISO 5208, pressure testing of metallic valves with leakage rate A ■ MSS SP-61, pressure testing of valves ■ DIN EN 12266-1, pressure tests, test procedures and acceptance criteria for industrial valves ■ API607/API6FA/ISO 10497 fire test for valves
Material requirements	<ul style="list-style-type: none"> ■ NACE MR0175 / ISO 15156, use in H₂S-containing environments in oil and gas production ■ Norsok M-630, specification for use in pipelines (Norway)
Marking	ASME B16.34, valves - flanged, threaded and welding end
Pressure-temperature limits (for diagram, see page 5)	The limits for operating pressure and temperature depend on the sealing material
Function (for functional diagram, see next page)	<ul style="list-style-type: none"> ■ Model IBM2: Block and bleed (shut off and vent) ■ Model IBM3: Double block and bleed (2 x shut off and 1 x vent)
Arrangement (for valve types, see next page)	The shut-off valve(s) and the vent valve can be defined individually as ball valve or needle valve.
Connection (inlet/outlet)	<ul style="list-style-type: none"> <li style="width: 50%;">■ ½ NPT female <li style="width: 50%;">■ G ½ female <li style="width: 50%;">■ ½ NPT male <li style="width: 50%;">■ G ½ male <li style="width: 50%;">■ ¾ NPT female <li style="width: 50%;">■ G ¾ female <li style="width: 50%;">■ ¾ NPT male <li style="width: 50%;">■ G ¾ male
Vent connection	½ NPT female or ¼ NPT female, plug screw is included in delivery, though not pre-fitted.

Functional diagram

Model IBM2

Block and bleed (shut off and vent)

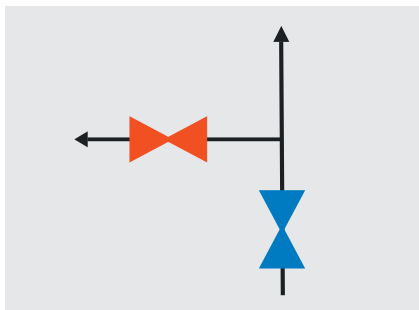

Model IBM3

Double block and bleed
(2 x shut off and 1 x vent)

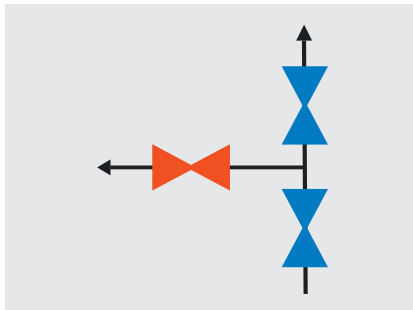

Colour code Blue: Shut off
 Red: Vent

Materials	
Wetted parts	
Valve body	<ul style="list-style-type: none"> ■ Stainless steel 316/316L (1.4401/1.4404) ■ Duplex F51 (1.4462) ■ Super Duplex F55 (1.4501) ■ Hastelloy C276 (2.4819) ■ Monel 400 (2.4360) ■ Carbon steel ASTM A350 LF2, class 2 ¹⁾
Valve fittings, ball, valve seats, valve stem, bonnet body, spindle tip	<ul style="list-style-type: none"> ■ Stainless steel 316/316L (1.4401/1.4404) ■ Duplex F51 (1.4462) ■ Super Duplex F55 (1.4501) ■ Hastelloy C276 (2.4819) ■ Monel 400 (2.4360)
Sealing	<ul style="list-style-type: none"> ■ PEEK (ball valve seat) ■ Graphite (needle valve sealing packing) ■ PTFE (needle valve sealing packing)
Non-wetted parts	
Handle, bonnet, valve spindle, locking plate, locking pin, product label, screws	Stainless steel
Handle grip	PVC

1) Valve body from carbon steel ASTM A350 LF2, the other wetted parts from stainless steel 316/316L (1.4401/1.4404). Unpainted carbon steel valves have an oil finish for corrosion protection during storage. This is not a substitute for paint or other protective coating to be applied at the place of use.

Other materials on request

Valve type

Ball valve

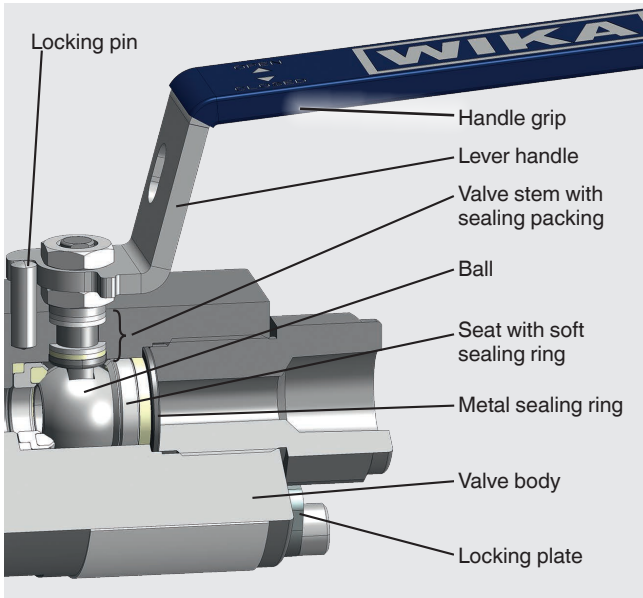

Needle valve

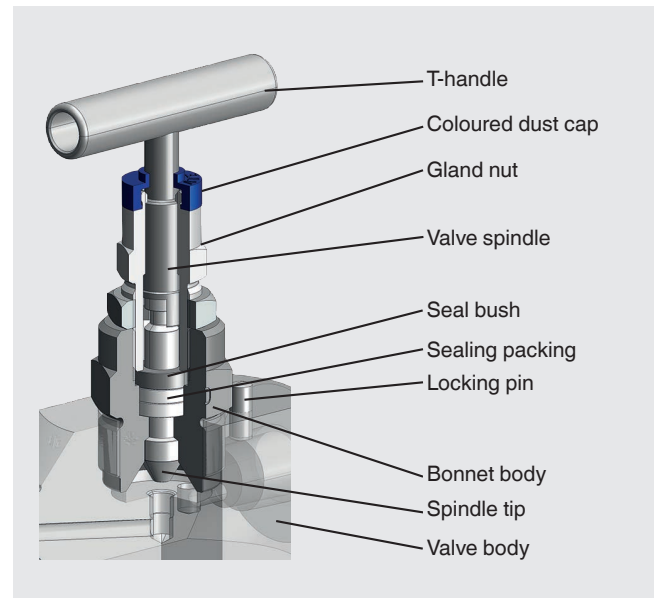

Specification	Ball valve	Needle valve
Design	<ul style="list-style-type: none"> ■ Antistatic design ■ Blow-out-safe valve stem ■ Self-relieving valve seats 	<ul style="list-style-type: none"> ■ Non-rotating spindle tip ■ Blow-out-safe spindle tip ■ Back seat design ■ Metal-to-metal seat
Colour code	Blue: Shut off Red: Vent	
Valve bore size	10 mm [0.394 in]	5 mm [0.197 in]

Options for ball valve

Anti-tamper version with padlock

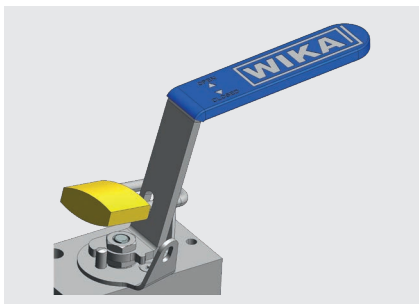

Extended lever handle



Options for needle valve

Anti-tamper version



Anti-tamper key



Anti-tamper version with padlock

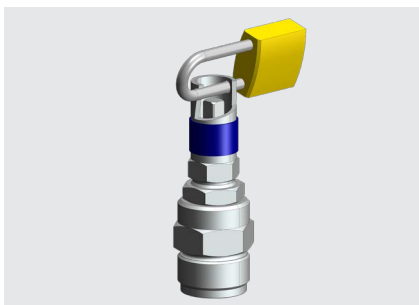

Extended lever handle



Pressure-temperature diagram

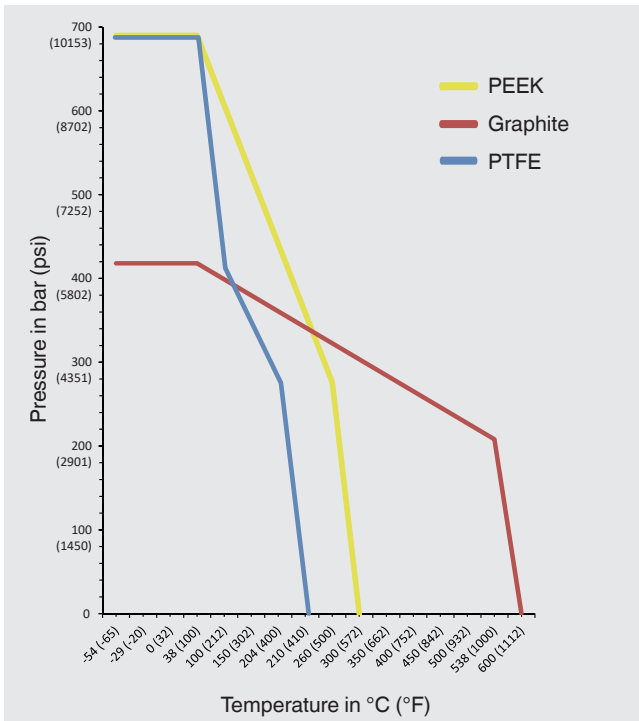

	Sealing material	Max. permissible operating pressure in bar at temperature in °C	Max. permissible operating pressure in psi at temperature in °F
Ball valve seat	PEEK ¹⁾	690 bar at 38 °C	10,000 psi at 100 °F
		276 bar at 250 °C	4,000 psi at 480 °F
Needle valve sealing packing	Graphite	420 bar at 38 °C	6,000 psi at 100 °F
		209 bar at 538 °C	3,030 psi at 1,000 °F
	PTFE	690 bar at 38 °C	10,000 psi at 100 °F
		276 bar at 204 °C	4,000 psi at 400 °F

1) Polyetheretherketone

The minimum design temperature is -54 °C [-65 °F]. For permanently low operating temperatures of ≤ -54 °C [≤ -65 °F], a special design is required.

Dimensions in mm [in]

Model IBM2

Shut off: 1 x ball valve

Vent: 1 x needle valve

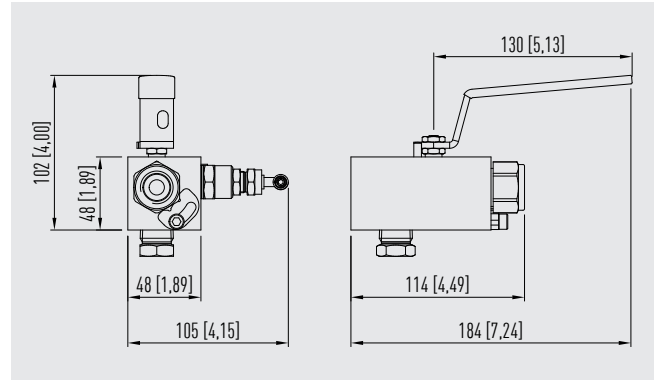
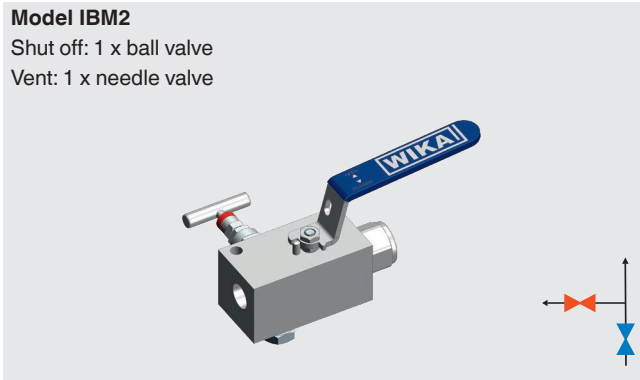

Model IBM2

Shut off: 1 x ball valve

Vent: 1 x ball valve

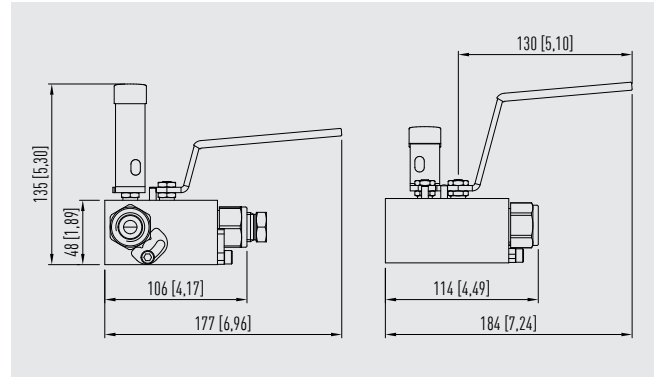
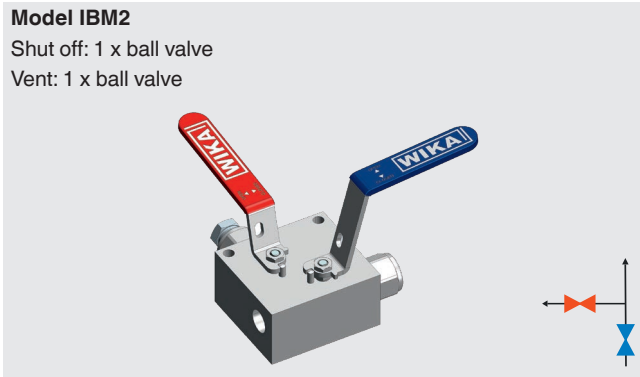

Model IBM3

Shut off: 2 x ball valve

Vent: 1 x needle valve

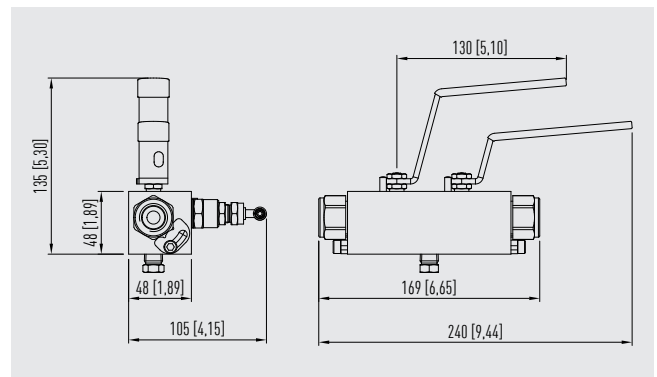
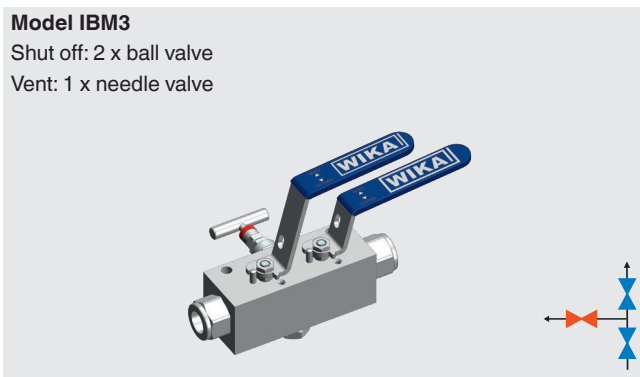

Model IBM3

Shut off: 2 x ball valve

Vent: 1 x ball valve

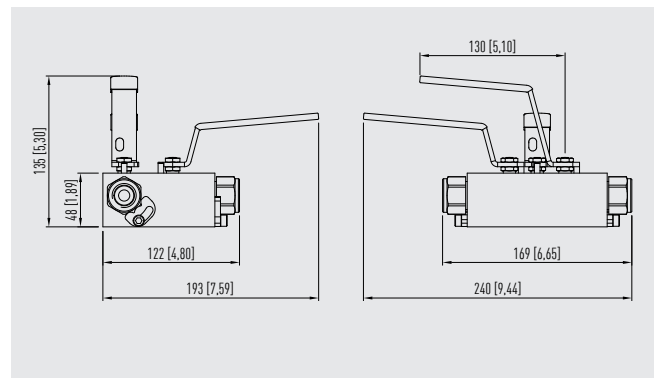
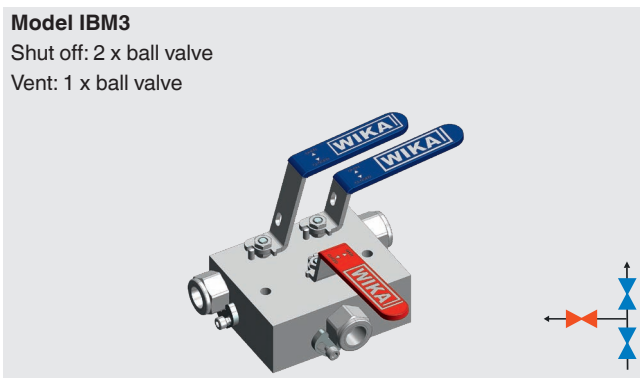

Approvals

Logo	Description	Country
	EAC (option) Machinery directive	Eurasian Economic Community

Manufacturer's information and certificates

Logo	Description
-	PMI ¹⁾ test certificate (option) All wetted parts
-	Type tested for fire safety in accordance with API 607, ISO 10497, BS 6755-2 ²⁾

1) Positive material identification
2) Only for ball valve

Certificates

- 2.2 test report per EN 10204
- 3.1 inspection certificate per EN 10204 (option)
 - Material certificate for all wetted parts per NACE MR0103/MR0175
 - Confirmation of pressure tests per API 598 ³⁾

3) Shell test: 15 s test duration with 1.5 times the permissible working air pressure
Seat test: 15 s test duration with 6 bar air/nitrogen



© 11/2019 WIKA Alexander Wiegand SE & Co. KG, all rights reserved.
The specifications given in this document represent the state of engineering at the time of publishing.
We reserve the right to make modifications to the specifications and materials.
In case of a different interpretation of the translated and the English data sheet, the English wording shall prevail.

